

Power Feeder Base DIY Kit | P/N: 8800994

Summary

The Power Feeder Base is an accessory for your favorite power feeder which allows it to be mounted to a ferrous steel table without drilling holes! Fabricate the wooden baseplate components, attach our 30x5 magnet arrays to it, and fasten your power feeder bracket.

Features

- Includes two 30x5 arrays for high holding strength
- Ratcheting arrays can be partially actuated for minor adjustment while positioning
- Wide footprint adds stability for long-reach feeders
- Knobs improve visibility of magnet ON/OFF state
- Modify your baseplate components to match your power feeder and add any extra features.

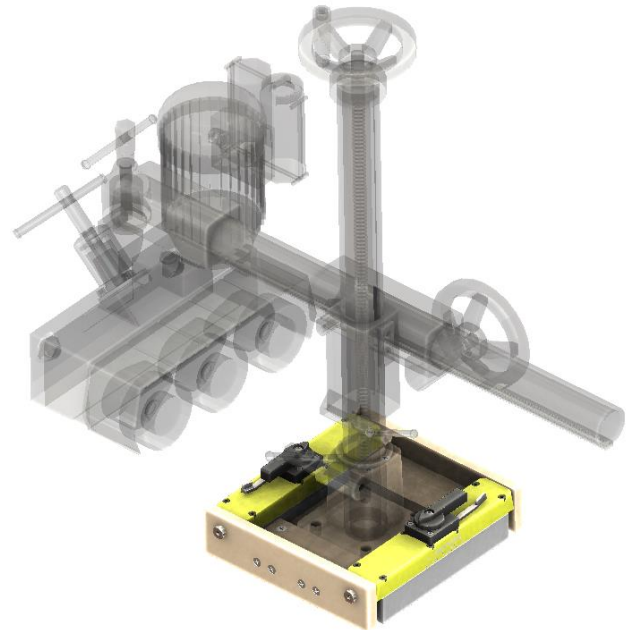

NOTE: Wooden components which hold magnets are not supplied as part of the kit!

WARNING!

Do Not Operate Unless In Contact With Ferrous Target

Specifications

Nominal Maximum Breakaway Force ¹	1172 lbs	532 kg
Nominal Maximum Shear ¹	51 lbs	23 kg
Net Weight	8.8 lbs	4.0 kg
Footprint	8.25" x 9.4"	210mm x 240mm

¹ Determined in laboratory environment on 2" thick SAE1018 Steel with surface roughness 63 micro inches with optimized pole shoes. Many factors contribute to the actual breakaway force and safe working load in each application. Consult a Magswitch Applications Engineer and test the Magswitch in each application before deployment.

CAUTION: The holding strength of the power feeder base is dependent on your feeder's configuration.

- **Always keep the over-arm length as close to the base as possible for best results.**
- **Always position the feeder head in such a way that if it slips it will not contact the table saw blade.**
- **Consult the next section for recommended feeding pressure.**

Performance

The following calculations will help estimate the maximum forces which can be exerted by the power feeder unit on the part before the base lifts or slips. The data used to calculate these forces assumes both magnet arrays are in good contact with a smooth, low-carbon steel table. Note that magnet strengths on high carbon (cast iron) tables can be as low as 40% of the values listed below.

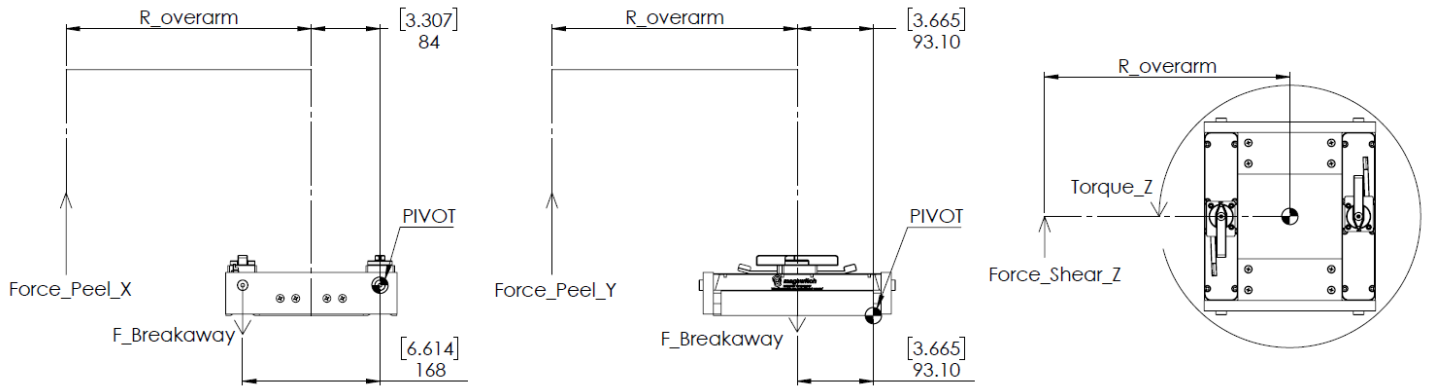

$$F_{Peel_X} (max) [kg] = \frac{F_{breakaway} [kg] \times 168 [mm]}{(R_{overarm} [mm] + 84 [mm])}$$

$$F_{Peel_X} (max) [lbs] = \frac{F_{breakaway} [lbs] \times 6.614 [in]}{(R_{overarm} [in] + 3.307 [in])}$$

$$F_{Peel_Y} (max) [kg] = \frac{F_{breakaway} [kg] \times 93.1 [mm]}{(R_{overarm} [mm] + 93.1 [mm])}$$

$$F_{Peel_Y} (max) [lbs] = \frac{F_{breakaway} [lbs] \times 3.665 [in]}{(R_{overarm} [in] + 3.665 [in])}$$

$$F_{Shear_Z} (max) [kg] = \frac{Torque_Z [kg \cdot mm]}{(R_{overarm} [mm])}$$

$$F_{Shear_Z} (max) [lbs] = \frac{Torque_Z [lb \cdot in]}{(R_{overarm} [in])}$$

The following is maximum breakaway and torque data for one 30x5 magnet array used in the above calculations. Only use the column of data which applies to the thickness of your saw table.

Material Thickness - mm (in)	0.6 (0.024)	1.2 (0.047)	1.9 (0.075)	3 (0.118)	3.5 (0.138)	4.76 (0.187)	6.35 (0.250)	9.5 (0.374)	12.7 (0.500)
Maximum Force ^{1,2,4} - kg (lbs)	21.83 (48.13)	61.67 (136.0)	91.83 (202.5)	127.2 (280.4)	138.8 (306.1)	182.8 (403.1)	243.5 (536.8)	265.7 (585.7)	265.8 (586.1)
Predicted Max Torque - kg·mm (in·lb)	1189 (93)	3360 (264)	5003 (393)	6928 (544)	7563 (594)	9960 (783)	13265 (1042)	14473 (1137)	14482 (1138)

¹ Determined in laboratory environment on 2" thick SAE1018 Steel with surface roughness 63 micro inches with optimized pole shoes. Many factors contribute to the actual breakaway force and safe working load in each application. Consult a Magswitch Applications Engineer and test the Magswitch in each application before deployment.

² Determined with SAE1018 Steel L=200mm W=200mm.

⁴ Values may vary by +/- 5%.

Safety

- Items or body parts between the gripping surface of the magnet and ferromagnetic material are at risk of crushing and impact forces.
- Never exceed the maximum rated load of Magswitch tools. This may result in an unsafe or dangerous condition.
- DO NOT attempt to alter the device in any way. This will void the warranty and may result in an unsafe or dangerous condition.
- DO NOT attempt to disassemble the Magswitch magnet; there are no user serviceable parts inside.
- All Magswitch products are designed for normal worksite/jobsite conditions. Do not use underwater or in a hazardous environment unless specifically designed for that purpose.
- DO NOT use a Magswitch product if it is damaged or not working properly. Severe injury can occur if this device is not used properly and safely.
- Ensure Magswitch MagJigs are stored in the OFF position when not in contact with ferromagnetic materials.
- DO NOT turn the magnet ON unless it is in contact with ferromagnetic metal. Actuation off-target will generate a strong, static, projected magnetic field which can accelerate, draw-in, and trap ferromagnetic material and damage magnetic storage media.
- DO NOT expose standard Magswitch tools to temperatures above 176°Fahrenheit (80°Celsius). High temperatures will permanently degrade the magnet's effectiveness and may result in an unsafe condition.
- Always keep the bottom of the magnet clean and free of debris and rust. If needed, wipe with WD40 or light oil. The bottom surface of the magnet must be flat, smooth, and in contact with steel to hold properly.
- Thicker steels will be held more strongly than thinner sheet. Steels with high alloy and carbon content will not be held as strongly.



WARNING: This product can expose you to chemicals including nickel and tetrafluoroethylene, which are known to the State of California to cause cancer. For more information, go to www.P65Warnings.ca.gov



WARNING: This product can expose you to chemicals including toluene, which are known to the State of California to cause birth defects or other reproductive harm. For more information, go to www.P65Warnings.ca.gov



WARNING: Drilling, sawing, sanding or machining wood products can expose you to wood dust, a substance known to the State of California to cause cancer. Avoid inhaling wood dust or use a dust mask or other safeguards for personal protection. For more information go to www.P65Warnings.ca.gov/wood.

Warranty

Magswitch Limited Warranty

Magswitch products are covered by a one year limited warranty on material and workmanship. Warranty is non-transferable. Magswitch reserves the right to inspect all product claims under warranty. Any alteration of the device voids this warranty. User assumes all risk for the proper use of this device and for ensuring product suitability for intended application. This warranty shall not cover any incidental or consequential damages due to the improper use or failure of this device. All Magswitch products are covered under International and U.S. Patents 6,707,360 & 7,012,495. Add'l patents pending.

All Magswitch products are covered under International Patents. Australian Patents: 753496, 2006294433, Canadian Patents: 2,392,772, 2,458,251, Chinese Patent: 254155, European Patent: 1243006, Indian Patent: 219575, Korean(South) Patent: 10-0728448, Mexican Patent: 236,352, New Zealand Patent: 518865, Singapore Patents: 88931; 103413, South Africa Patents: 2002/3752; 2004/1785, US Patents: 6,707,360; 7,012,495. Additional Patents and Patent Applications Pending in Hong Kong, South Korea, China, Spain, Brazil, China, Japan. Trade Mark Registered in: European Union, Germany, Brazil, China

Assembled Product Dimensions

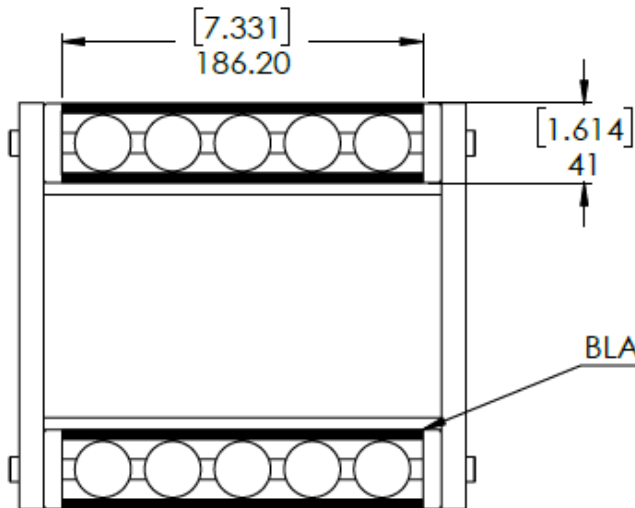
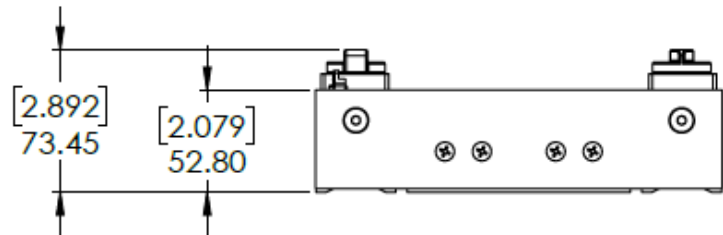
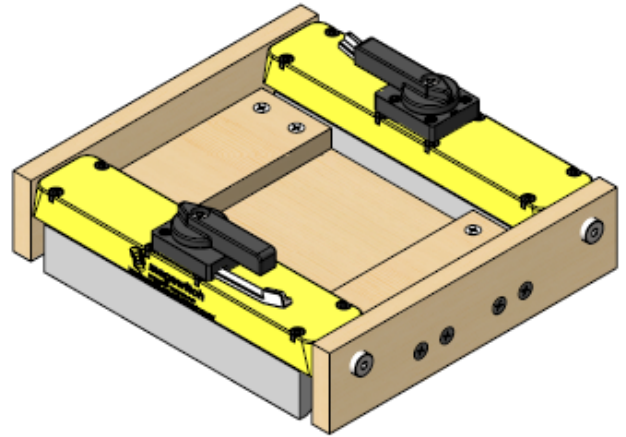
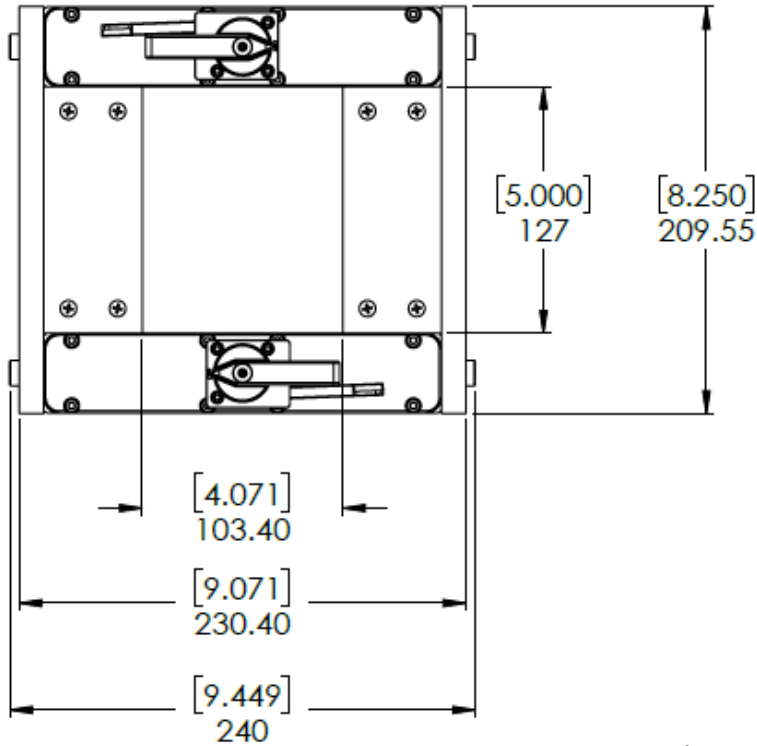

BLACK = Primary Working Surface

8800994 Kit Materials

PART NUMBER	DESCRIPTION	QTY
400235	9"x6"x2mm cork sheet (oversized)	1
8000919	30x5 Array with Ratchet Handle	2
1801027	Shoulder Bolt, M6, 7mm Thread Length	4
1801431	5x30mm wood screw	8
1801759	#8x7/8" flat head wood screw	8

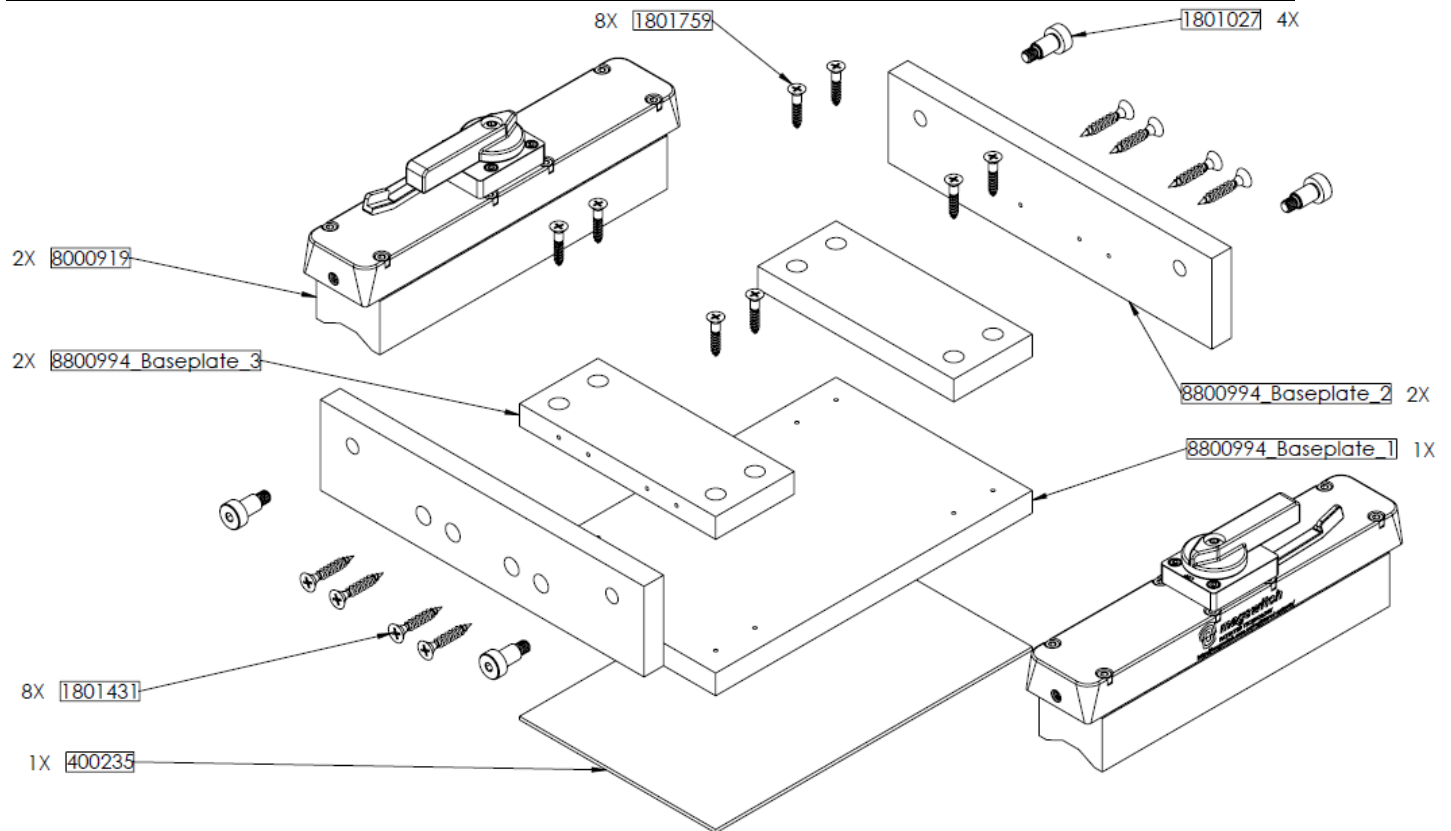

Additional Materials (not included in kit 8800994)

PART NUMBER	DESCRIPTION	QTY
8800994_baseplate_1	8800994_Baseplate_1 (1/2" plywood)	1
8800994_baseplate_2	8800994_Baseplate_2 (1/2" plywood)	2
8800994_baseplate_3	8800994_Baseplate_3 (1/2" plywood)	2
	Wood glue and/or CA (cyanoacrylate) super glue and/or contact cement	A/R
	Flat head bolts and hex nuts to attach your power feeder to Baseplate_1	A/R

Tools

- Table Saw
- Miter Saw
- Drill press
- 3/32" Drill Bit
- 8mm or 5/16" Drill Bit
- #2 Phillips Driver
- 82° Countersink for #8 screws
- 4mm allen key
- Utility razor/knife
- Drill bit to match hardware used to attach your power feeder bracket to Baseplate_1
- Countersink tool to match flat head screws used to attach your power feeder bracket to Baseplate_1
- Metric and SAE Tape Measure or Square

Parts Plan 1: 8800994_Baseplate_1 (1/2" plywood)

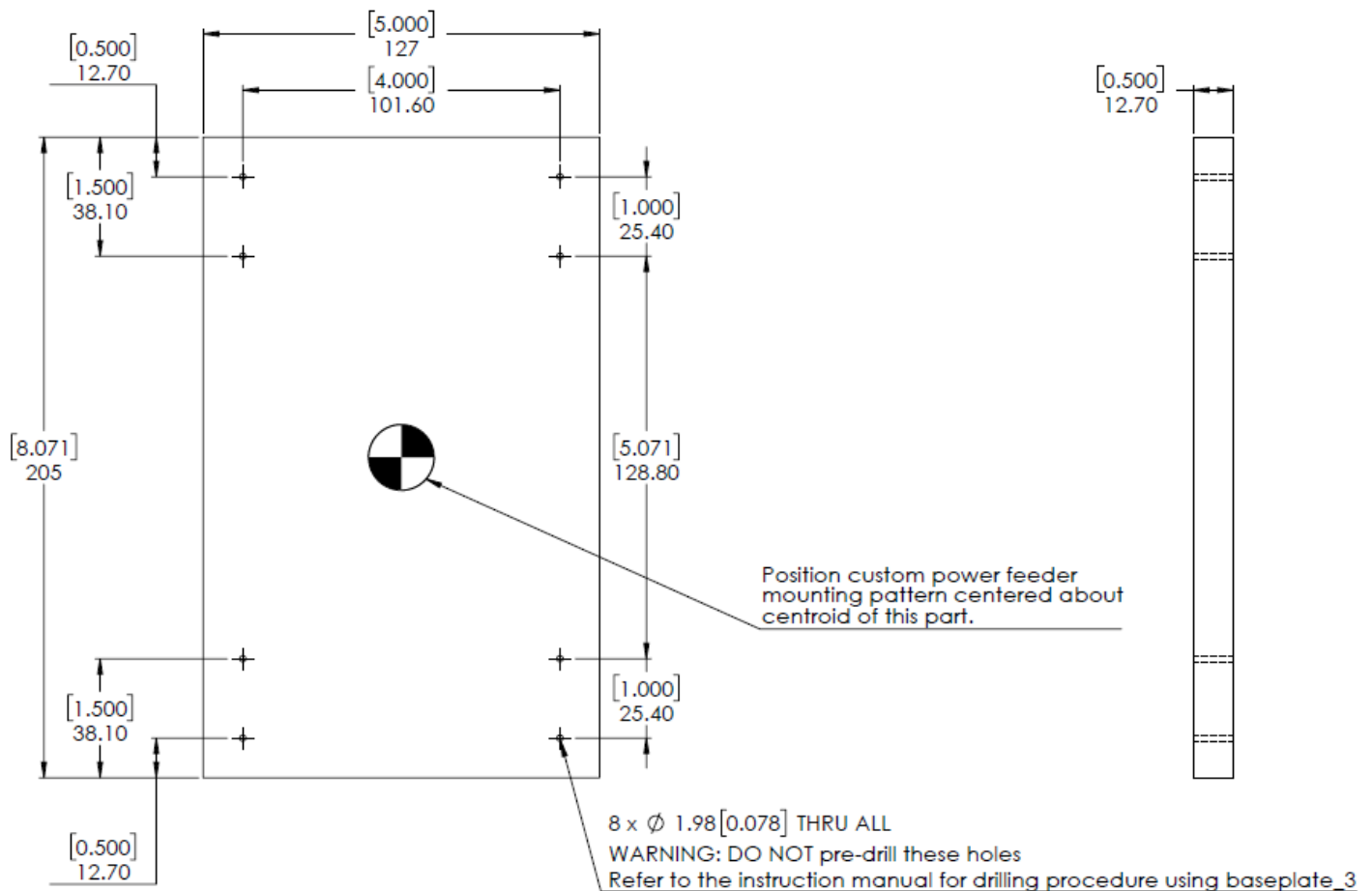

Parts Plan 2: 8800994_Baseplate_2 (1/2" plywood)

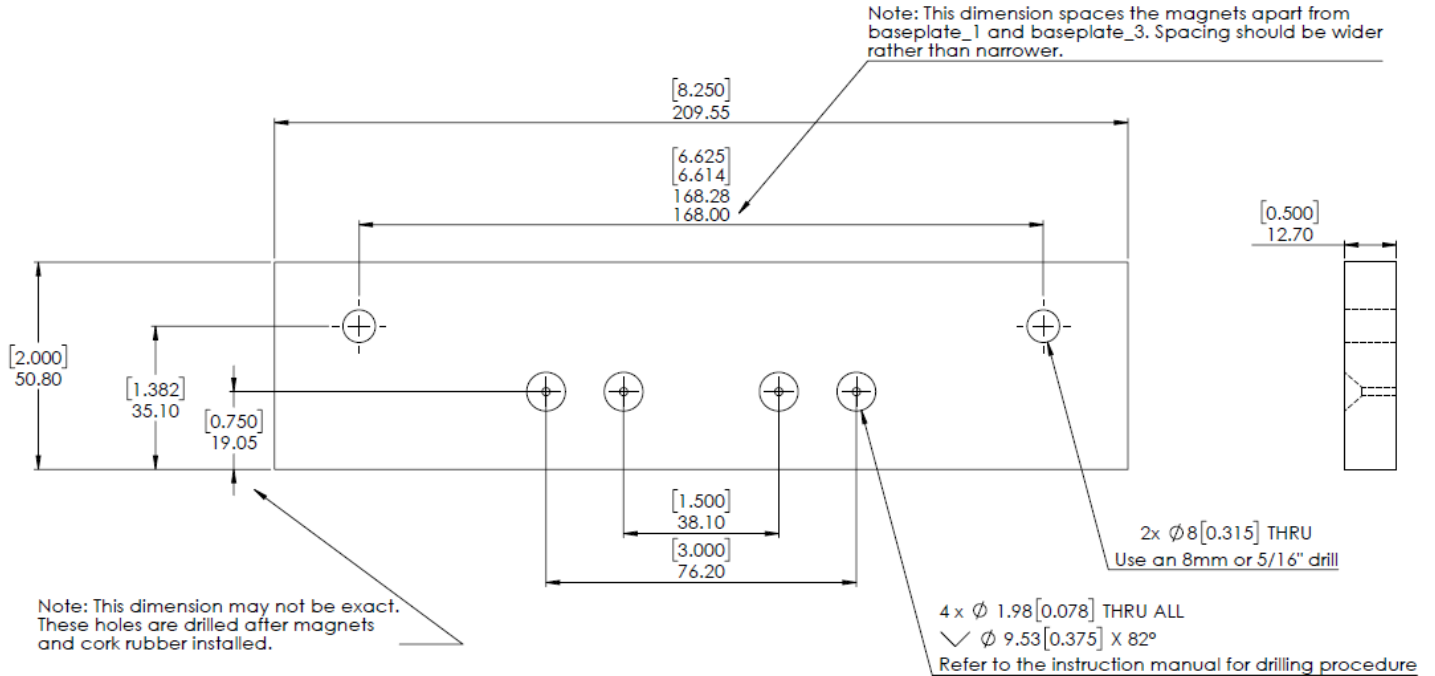

Parts Plan 3: 8800994_Baseplate_3 (1/2" plywood)

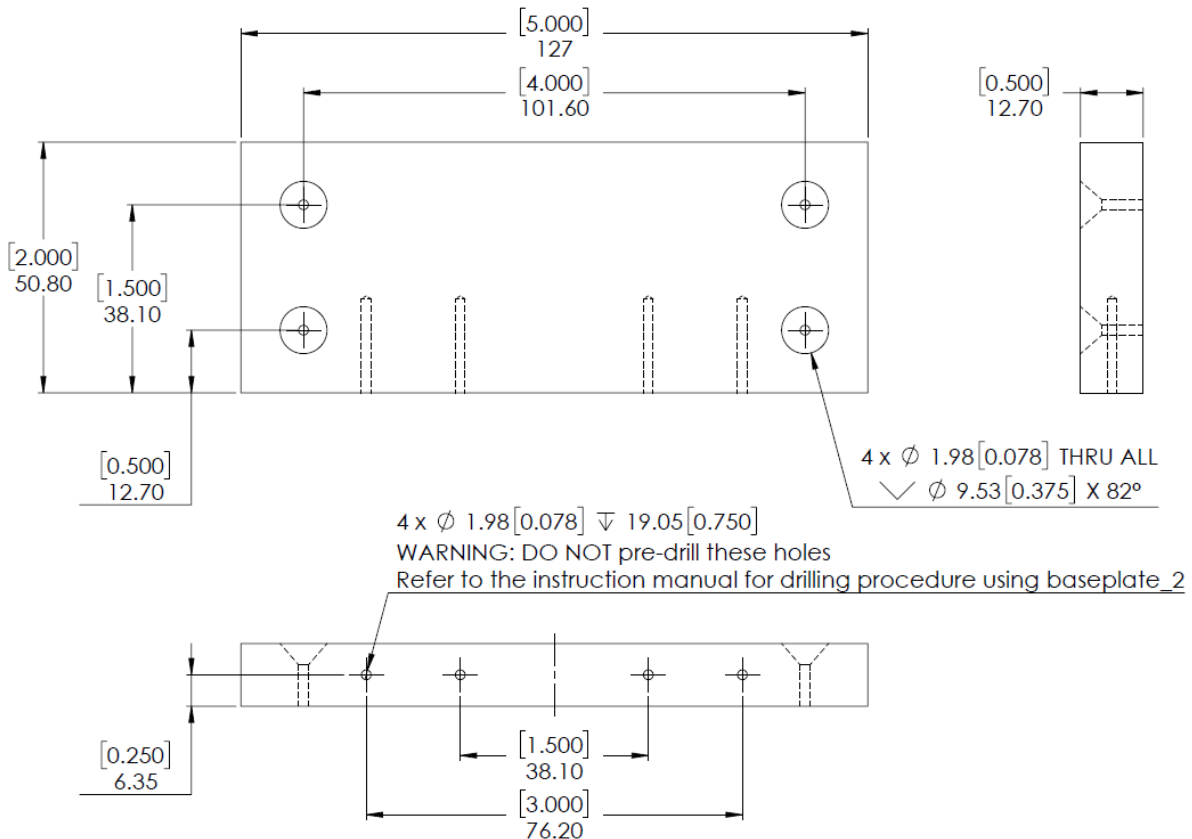

Assembly Instructions

1. Rip and trim the five Baseplate components from 1/2" plywood. When trimming Baseplate_1 to length, the 205mm [8.07"] dimension is critical because it must match the length of both magnets. If needed, use the length of the yellow magnet "cap" to mark this length. Making multiple trim cuts will help you creep up on this critical dimension.
2. Loosely assemble the five Baseplate components as shown to verify the edges are flush with the magnet arrays and that there are no large gaps.
3. Test fit the Baseplate_3 blanks on Baseplate_1 with your power feeder attachment bracket as shown to confirm it will fit within the perimeter. If it will not fit, adding extra width to these parts may be necessary. Adding width to this base will make it more stable. Removing width from the base is not recommended, as can be "peeled" off the table more easily if the feeder is pushing down too hard.
4. Apply wood glue, cyanoacrylate (CA) glue, or rubber cement between both Baseplate_3 components and Baseplate_1. Make sure all edges are flush.

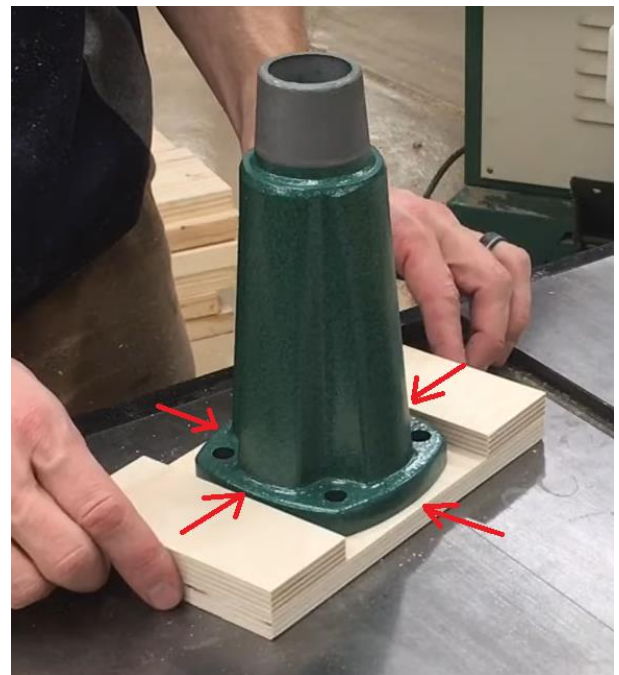
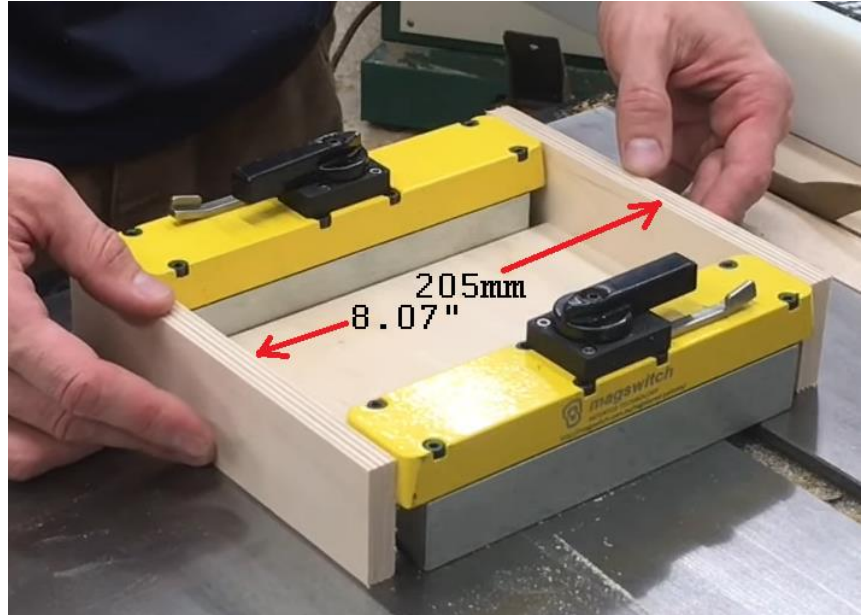

5. Pre-drill, countersink, and screw the 8x #8 x 7/8" wood screws through Baseplate_3 into Baseplate_1 at the locations shown. Use a 3/32" drill bit and an 82° countersink tool.



6. If the screw heads are countersunk too deep, the tips of the screws will poke out the bottom of Baseplate_1. If this happens, sand/grind the screw tips flush with the plywood.
7. Separately, drill the two 8mm / 5/16" holes in the two Baseplate_2 parts. These holes will space the two magnet arrays apart enough to snugly fit the Baseplate_1 + Baseplate_3 assembly between them. If these two holes are drilled too closely together, the Baseplate_1 + Baseplate_3 assembly can be sanded to fit.



8. Install the (1801027) M6 shoulder screws through the 8mm / 5/16" holes drilled in Baseplate_2. This may require the use of a hammer, so beware of splintering the plywood.

9. Use a 4mm allen key to tighten the four shoulder screws through both Baseplate_2 parts into the threaded holes in the yellow “caps” of both magnet arrays as shown. Sand or trim the Baseplate_1 + Baseplate_3 assembly so it fits snugly between the magnet arrays with the shoulder screws tightened.



10. Unwrap and flatten the 400235 cork sheet. It will ship to you oversized. Spray or paint one side of the cork material with adhesive. Apply adhesive to the underside of the Baseplate_1 + Baseplate_3 assembly and smooth it out so a thin layer remains. Excess or uneven adhesive can cause bubbles which will make the bottom of the base uneven (which can impact holding force).



11. Flip the Baseplate_1 + Baseplate_3 assembly upside-down and adhere it to the cork sheet. Apply firm pressure to eliminate air bubbles between the cork and plywood.



12. Use a utility/razor knife to trim the extra cork from the perimeter of the Baseplate_1 + Baseplate_3 assembly so all edges are flush.

13. With the cork layer installed, mark and drill the bolt pattern for your specific power feeder bracket through Baseplate_1. Center the drill pattern in the middle of the baseplate.



14. Use a countersink/chamfer tool to countersink each of the power-feeder-specific mounting holes deep enough so your custom flat head bolts will sit flush or below-flush in the holes.



15. Attach the power feeder base bracket to the baseplate assembly using flat head countersunk bolts.

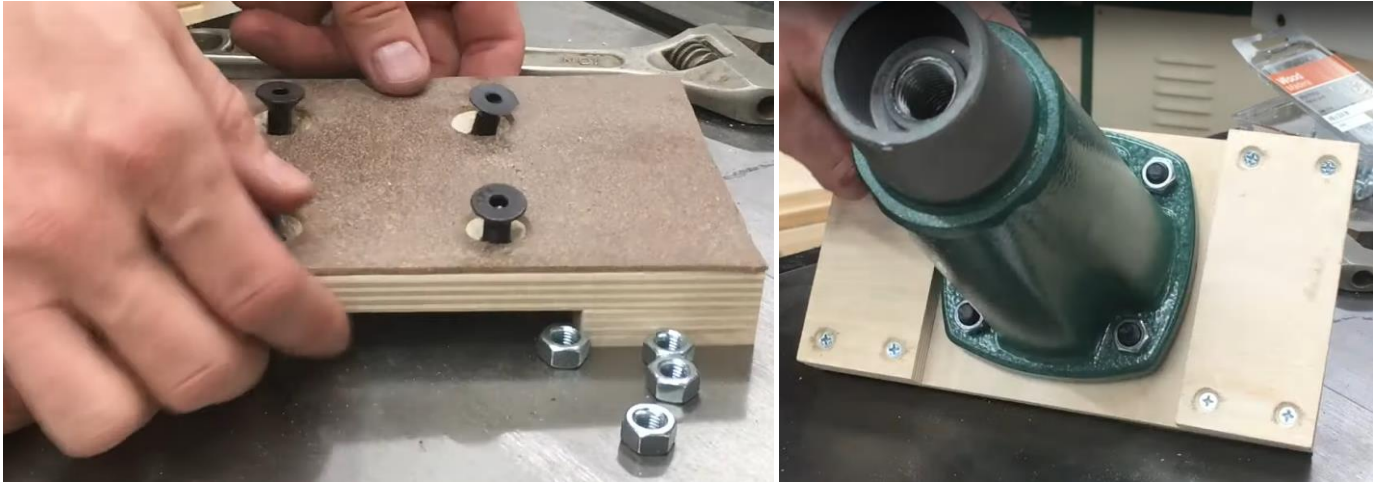

16. Slide the [magnet + baseplate_2] assembly over the [power feeder base+baseplate_1+baseplate_3] assembly on a steel surface (such as a table saw). Insert two layers of construction paper underneath both magnet arrays (but not underneath the cork material). The paper props the magnets up a little bit during assembly so when the magnets are turned on later they compress the cork slightly.



17. Turn both magnet arrays ON by rotating the black knobs clockwise 180°. A ratchet is built-in and will make a clicking noise when turning. The magnets can be turned OFF by pressing the ratchet release lever shown below, then rotating the knob counterclockwise 180°.

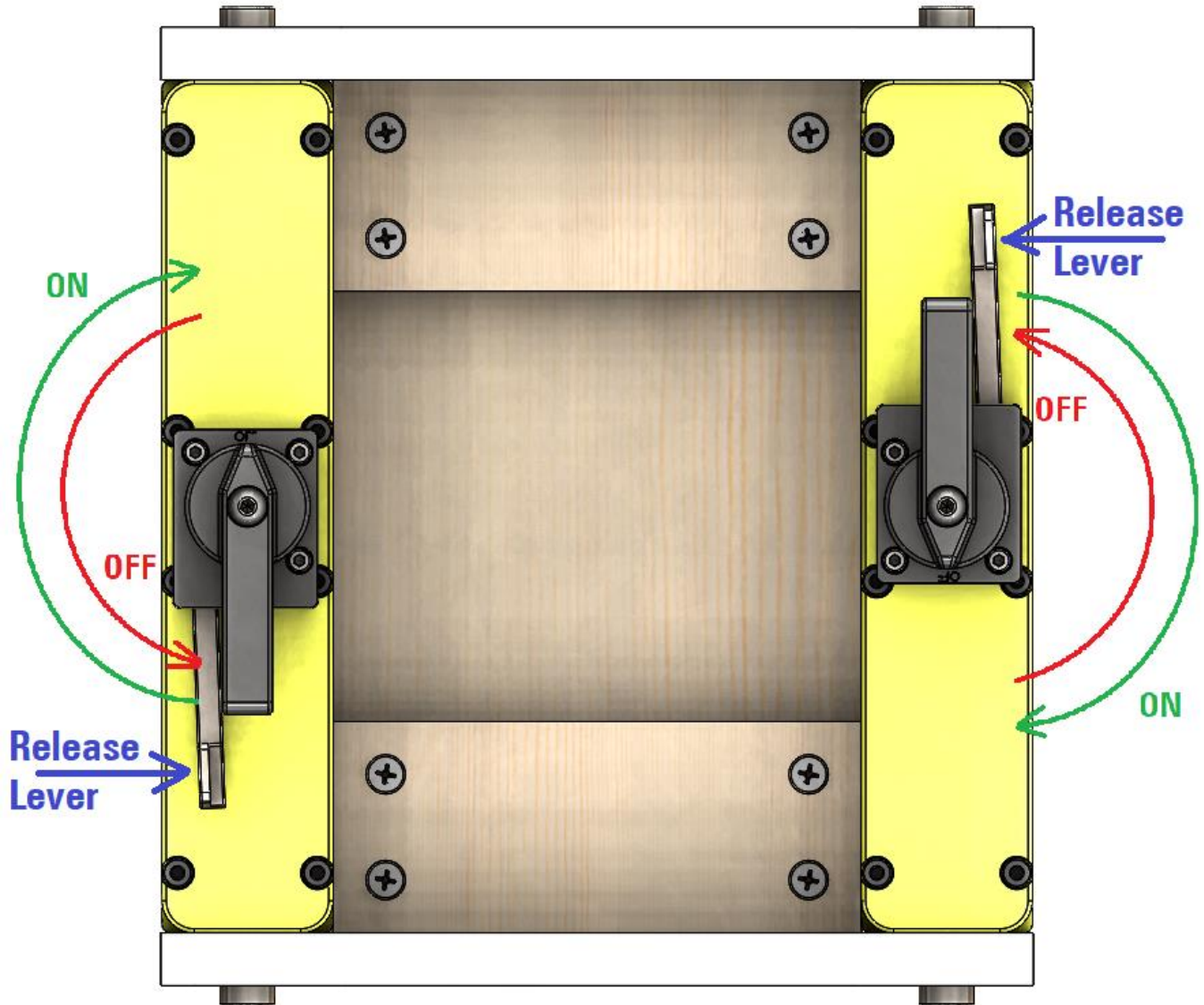

18. With the two layers of construction paper underneath both magnets and the magnets turned on, pre-drill, countersink, and screw the (1801431) 5mmx30mm wood screws through Baseplate_2 into Baseplate_3 at the locations shown. Use a 3/32" drill bit and an 82° countersink tool.

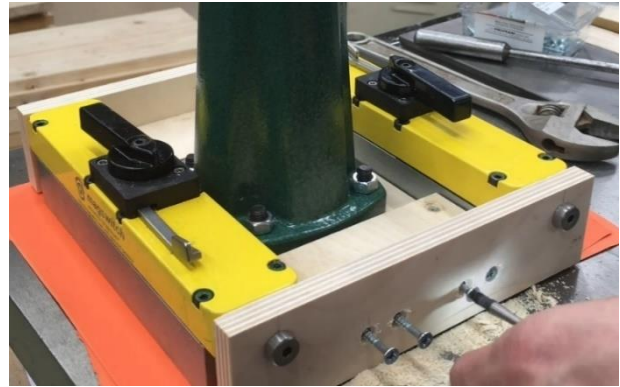
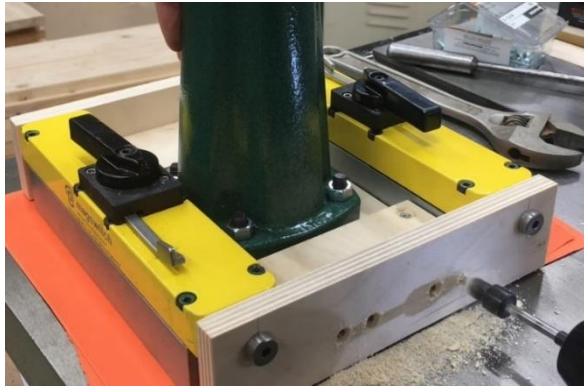

19. Turn OFF both magnet arrays and attach the arm and feeding unit of the power feeder to the magnetic base. Verify that there are no gaps between the bottom surface(s) of either magnet array and the saw table.

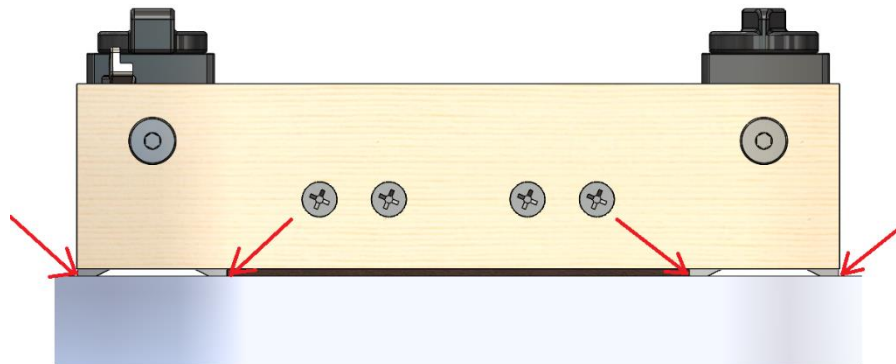

20. To verify functionality and set up the feeder for the first time, lower the table saw blade and run a few pieces of stock along the fence past the blade groove to ensure the feed angle and speed is correct, and that the downward pressure is acceptable.
- Thoroughly read and follow all instructions provided with your power feeder; all setup and safety precautions still apply when using a magnetic base.**
 - If one side of the magnet base peels upward when feeding, try reducing the downward force the feeder applies on the stock against the table.
 - If the power feeder base twists on the table saw, verify that both magnets are in full contact with the saw table and that the cork material is in contact as well. As the cork wears over time, it may become necessary to replace with more 2mm cork or rubber.
 - If problems persist, please consult Magswitch customer service through our online web portal at www.magswitch.com or by phone at 303-468-0662.

EU Declaration of Incorporation for Partly Completed Machinery

We, Magswitch Technology

Magswitch Technology World Wide Pty. Ltd.

Registered Office: C/- Shop 2B, 14 Short Street, Port Macquarie NSW 2444 Australia

Declare with sole responsibility that the partly completed machines

Power Feeder Base DIY Kit or other tool designations containing the "DIY Kit" description and any accessories for these designations covered by these directives

Comply with the essential requirements of 2006/42/EC

The relevant parts of the directive are defined more precisely in the technical documentation compiled in accordance with Section B Annex VII and, for a justified cause, can be made applicable in digital form for any relevant authorities.

And also conform to the relevant Union harmonisation legislation:

- 2011/65/EU Restriction of Hazardous Substances Directive (RoHS 2)
- 2015/863 Restriction of Hazardous Substances Directive III (RoHS 3)

Conformity is shown by compliance with the applicable requirements of the following documents:

Ref:	Title	Date
ISO 12100	Safety of machinery - General principles for design - Risk assessment and risk reduction	2010

Per Annex II.B of the Machinery Directive:

This product may not be taken into operation before the complete system into which it has been built has been declared to conform to the provisions of Directive 2006/42/EC.

The Technical Construction File is maintained at:Magswitch Technology, Inc.
1355 Horizon Ave, Lafayette CO 80026
ph. 303.468.0662 fax 303.951.9918**The authorised representative located within the Community is:**Cengiz Kizilkan
President Automation Sales
Magswitch Technology Europe
Marie-Curie-Str. 2
D-85055 Ingolstadt, Germany**Date of issue:** 1/10/2020**Place of issue:** Lafayette, Colorado, United States of America

David C. Long, Magswitch Engineering